



IMPORTANT

Carefully remove all the parts from the carton and place them individually on a soft cloth to prevent scratches or other damage.

Carefully and strictly follow these assembly instructions to ensure a completed product as designed.

Do not use power tools above 8 volts to assemble.

Part List

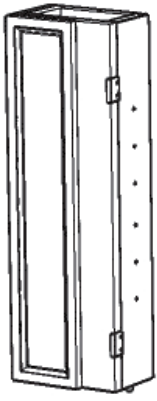

I.
Post
1 pc.



J.
Post
1 pc.

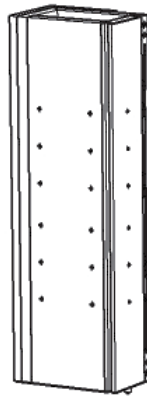

K.
Post
1 pc.

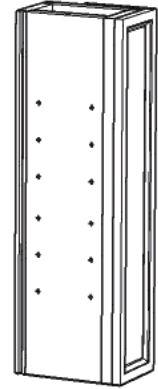

L.
Post
1 pc.



M.
Side Panel
2 pcs.

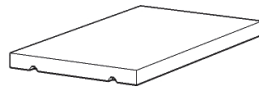

O.
Shelf
4 pcs.

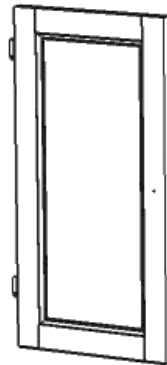

P.
Door
1 pc.

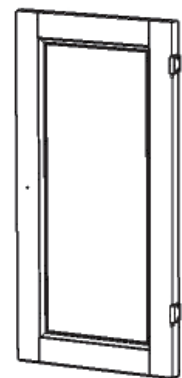

Q.
Door
1 pc.

Cartons 5003-941, 942 are also needed for assembly.

Tool(s) required for assembly: Phillips screwdriver, Level

Home Styles Customer Service: www.homestylesfurniture.com,
servicedesk@homestylesfurniture.com, 888-680-7460, 877-831-0319

Assembly Instructions 2/6

IMPORTANT

- Use a soft cloth between these parts and the floor.
- Do not use power tools above 8 volts to assemble.
- Do not tighten all the bolts until each part is properly assembled.
- The unit must be level to work properly. Use the included adjustable levelers to level.
- Keep Hex Wrench as the bolts may need to be tightened in the future.

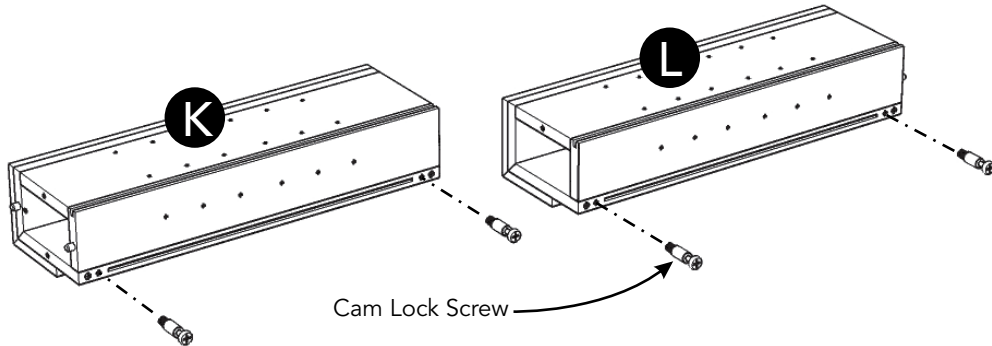

STEP 1

Insert Cam Lock Screws into pre-drilled holes in Posts (K) and (L), then tighten. (See Figure 1)

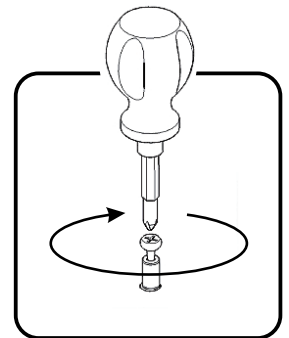
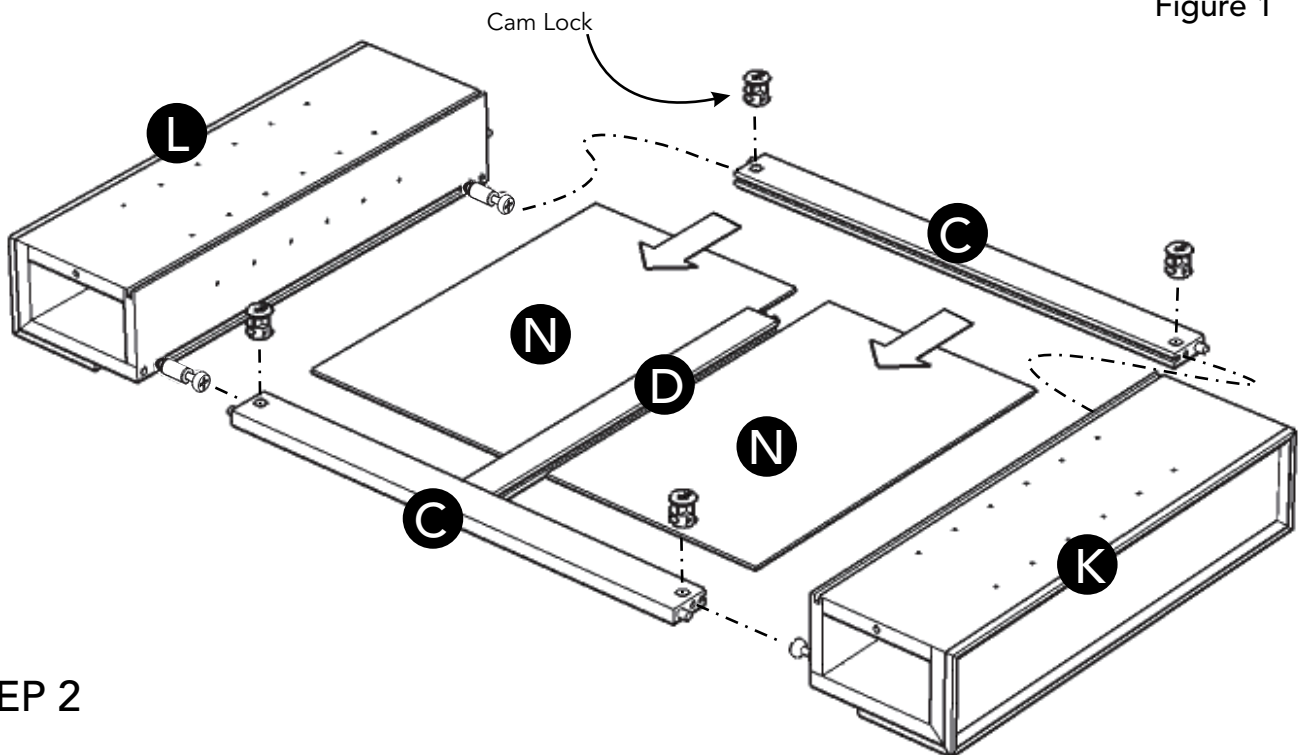

Figure 1



STEP 2

Attach Back Rail (C) to Post (K) with Cam Lock.
(See Figure 2)

Attach Back Upright (D) to Back Rail (C).

Slide Back Panels (N) into position.

Attach Back Rail (C) to unit with Cam Lock.

Attach Post (L) to unit with Cam Locks.

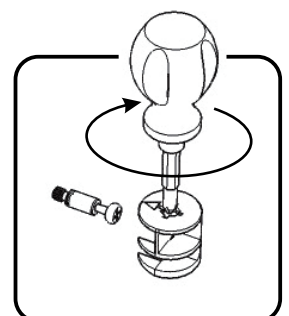

Figure 2

Assembly Instructions 3/6

STEP 3

Attach unit and Middle Panel (E) to Base (H) with Head Cap Bolts. (See Figure 3)

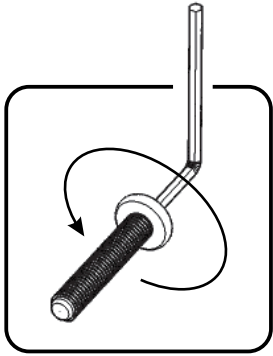
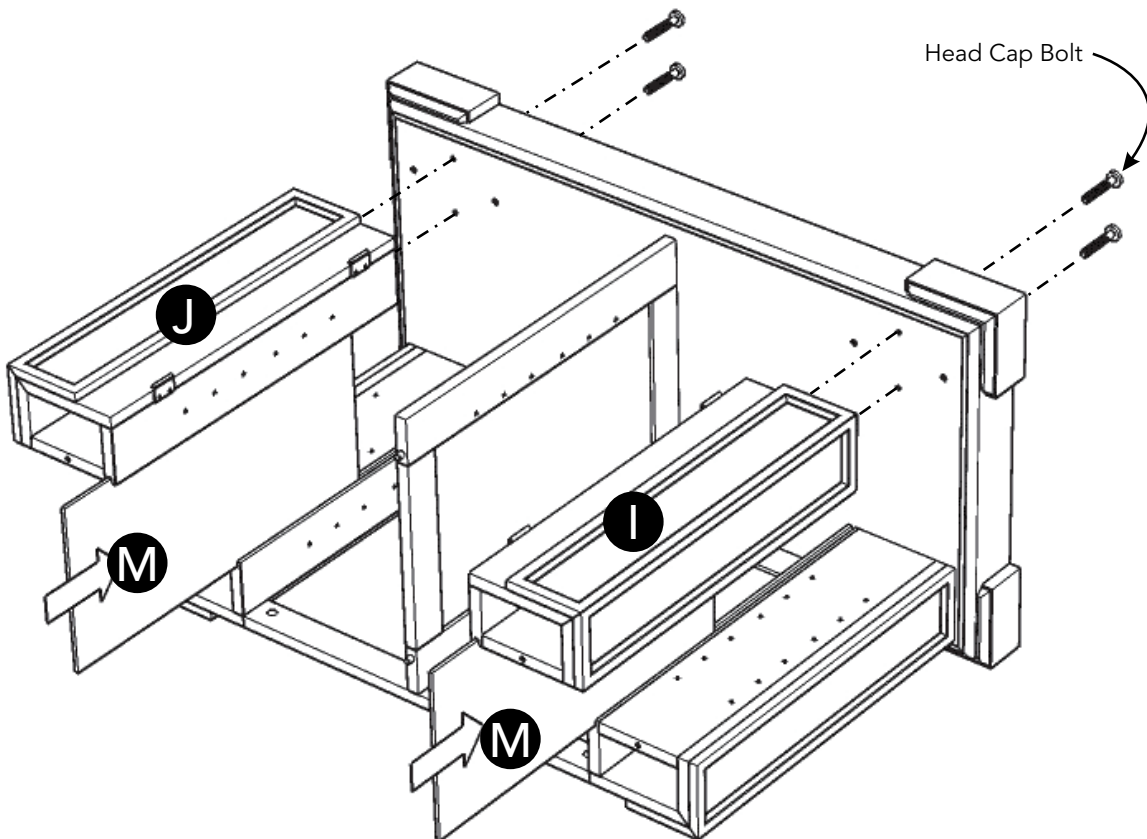
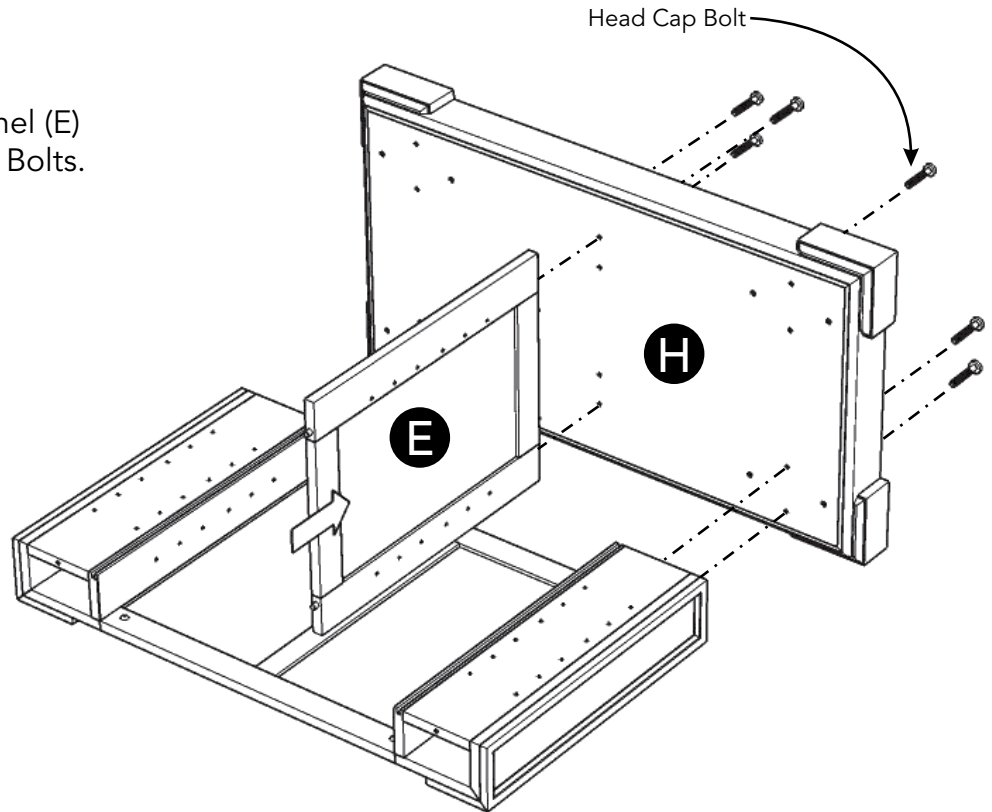

Figure 3



STEP 4

Attach Posts (I) and (J) to unit with Head Cap Bolts.

Slide Side Panels (M) into position.

Assembly Instructions 4/6

STEP 5

Attach Rails (F) to unit with Head Cap Bolts.

Insert Adjustable Pins into posts and middle panel at desired level. (See Figure 4)

Place Shelves (G) and (O) into position.

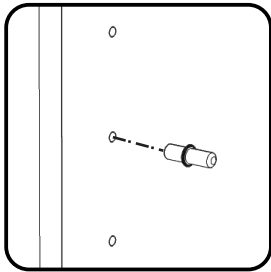
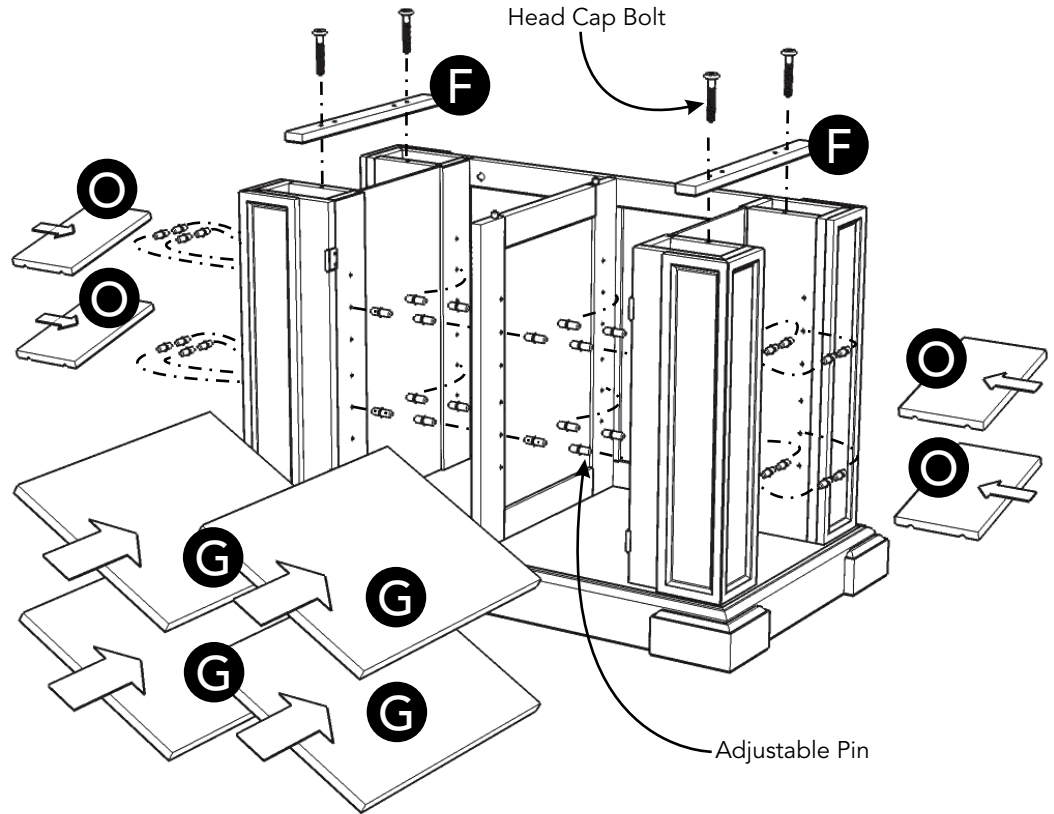

Figure 4

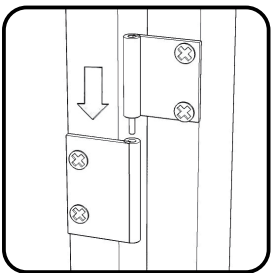

Figure 5

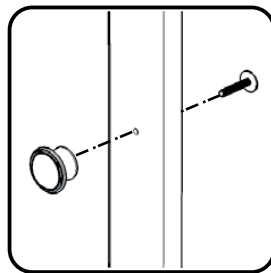
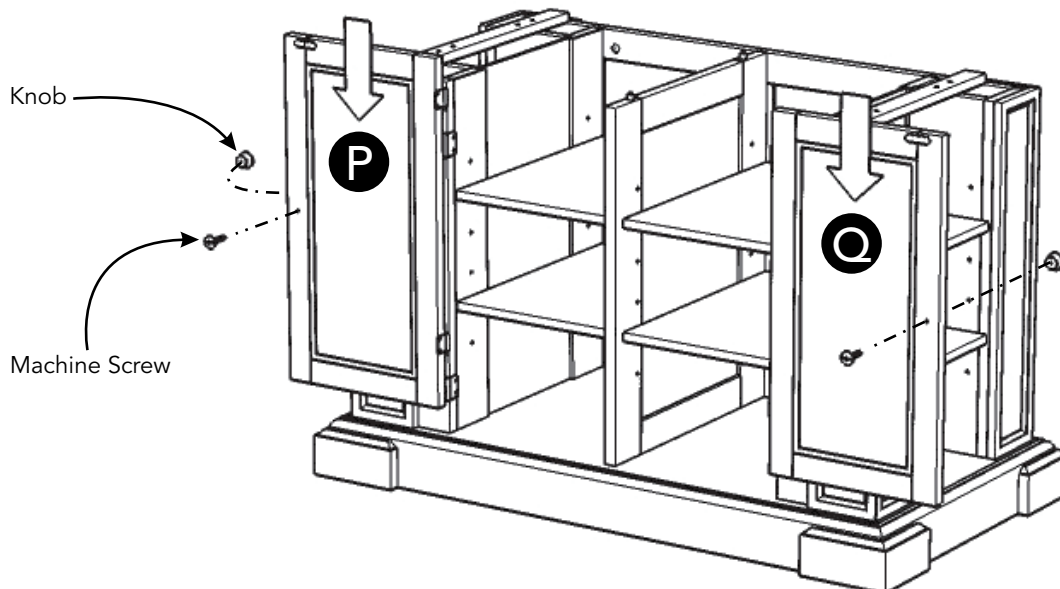

Figure 6

STEP 6

Attach Doors (P) and (Q) to unit by sliding door hinges into post hinges. (See Figure 5)

Attach Knobs to Doors (P) and (Q) with Machine Screws. (See Figure 6)



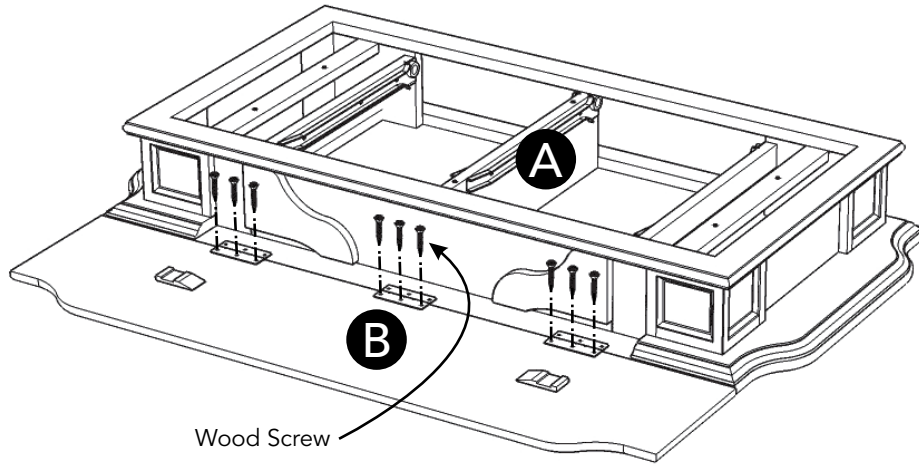

STEP 7

Remove drawers from Top Unit (A).

Place Top Unit (A) and Leaf Top (B) upside down on a soft cloth.

Attach Top Unit (A) to Leaf Top (B) with Wood Screws into pre-drilled holes. (See Figure 7)

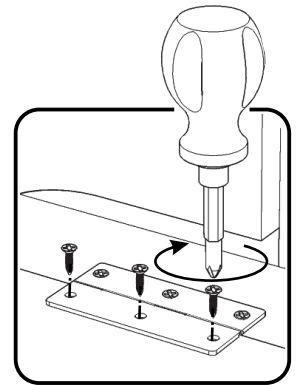
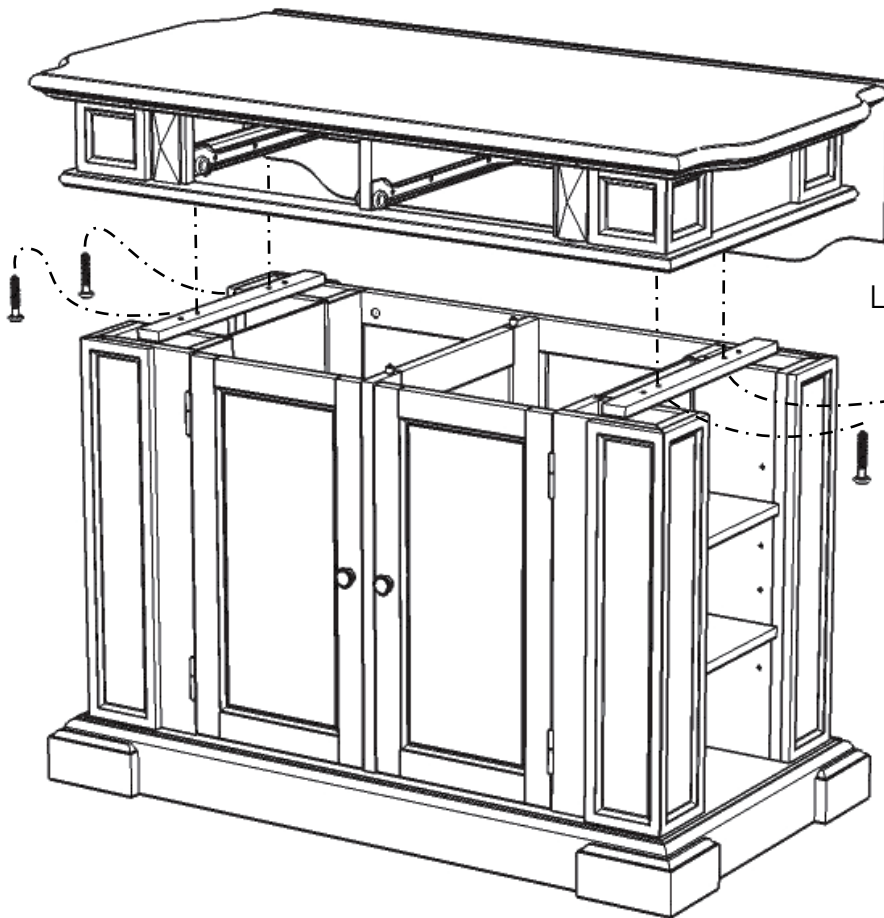

Figure 7



STEP 8

Attach top unit to unit with Head Cap Bolts.

Level unit by adjusting the adjustable levelers on bottom of unit. (See Figure 8)

Note: Unit must be level to work properly.

Head Cap Bolt

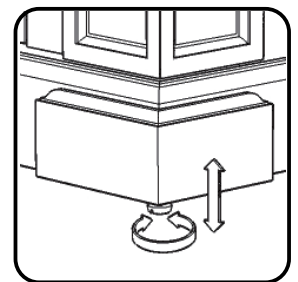
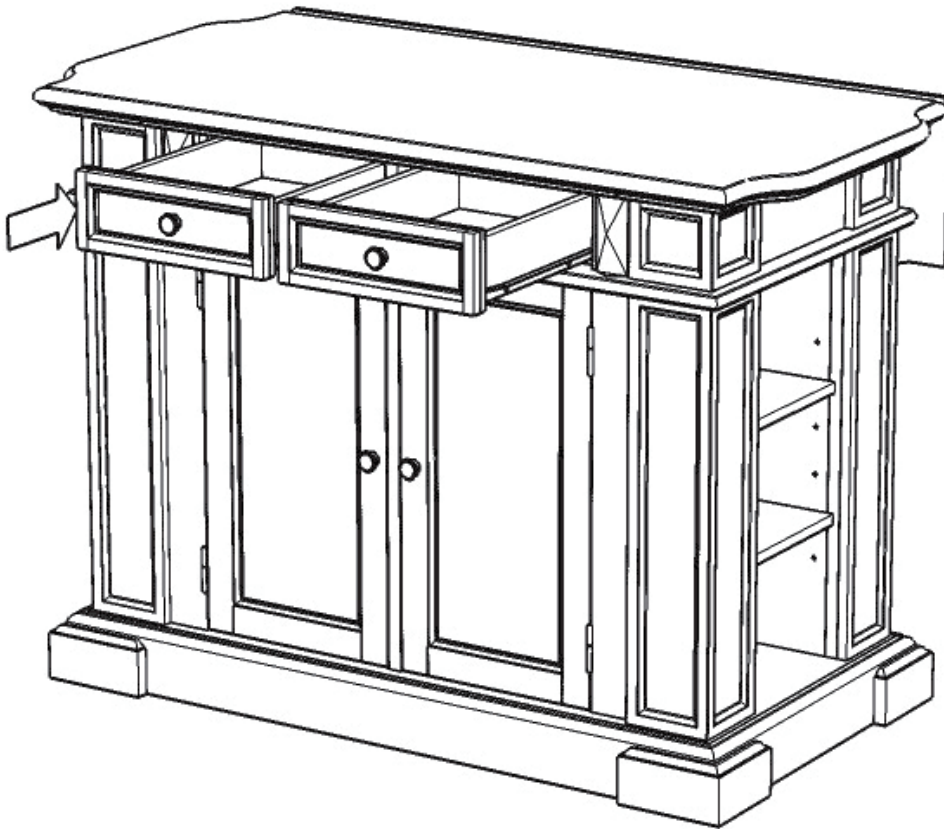
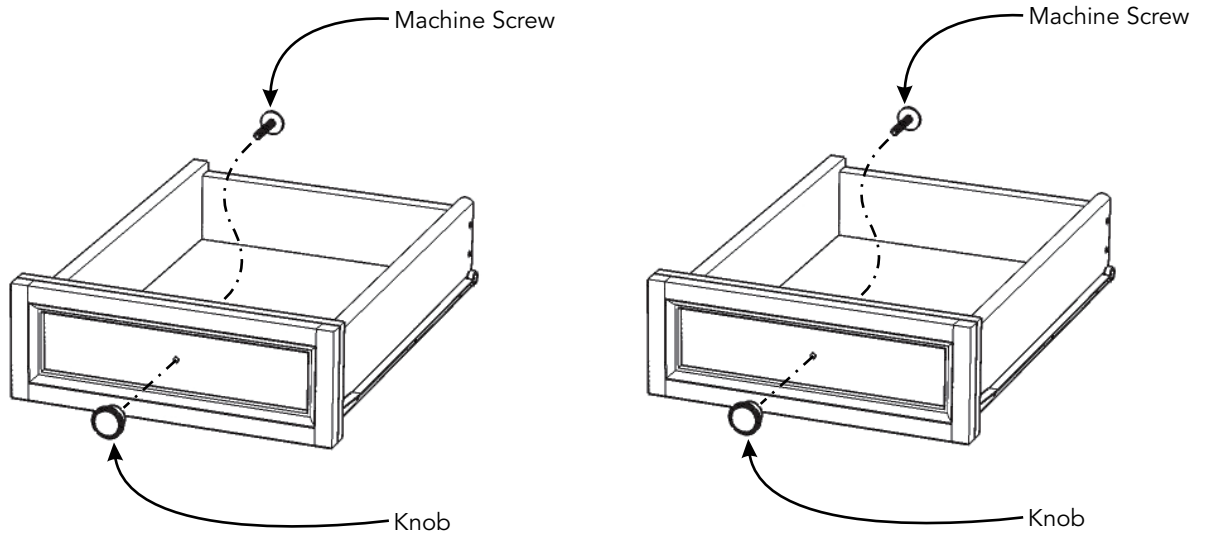

Figure 8

Assembly Instructions 6/6

STEP 9

Attach Knobs to drawers with Machine Screws.



STEP 10

Slide drawers into position.

CARE INSTRUCTIONS

NEVER

allow liquids to remain on furniture.
Absorption causes parts to warp
and split and finishes to delaminate.

NEVER

use glass cleaners on
finished furniture. Ammonia
chemically attacks the finish.



Do not use power tools
above 8 volts to assemble.

**PREVENT
CRACKING**



Do not place
in direct sunlight.

**PREVENT
FADING**



Do not write
directly on surface.

**PREVENT
MARKING**



Do not place hot
objects on surface.

**PREVENT
FINISH DAMAGE**

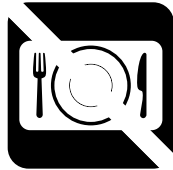

Do not use rubber
based placemats.

**PREVENT
DISCOLORING**



Do not use commercial
waxes and polishes.

**PREVENT
YELLOWING**

CLEAN

with a soft cloth moistened
in lukewarm soap and water.
Buff with a dry clean cloth.



Home Styles will provide replacements free of charge for missing or damaged hardware or parts within 30 days of purchase. Digital images of the defective parts may be required. If the product was not purchased from an authorized retail affiliate, Home Styles is under no obligation to provide replacement parts. Parts are not available for fully assembled items nor are parts available for sale. Replacements for missing or damaged hardware or parts may be requested at:

www.homestylesfurniture.com/customer-service/replacement-parts

Home Styles Customer Service: www.homestylesfurniture.com,
servicedesk@homestylesfurniture.com, 888-680-7460, 877-831-0319